

VEK MNH

Traffic detector

Operating manual

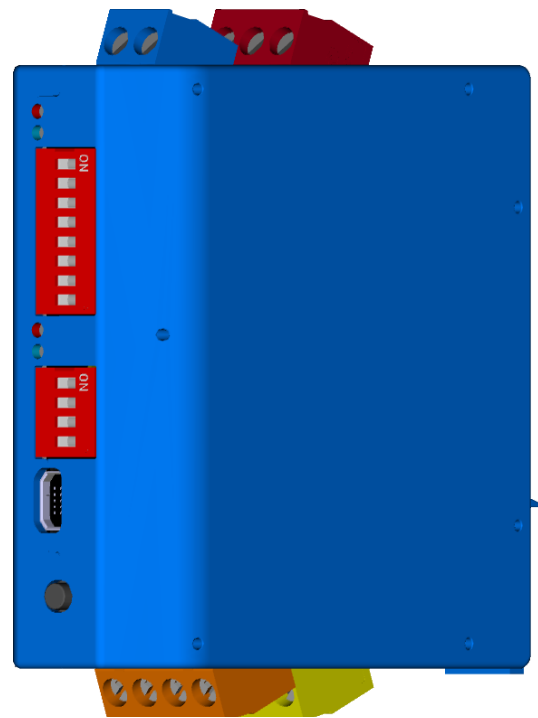

EN

IMPORTANT

Read these instructions carefully before use!

Keep these instructions at hand!

Read the safety instructions on page 12!

EN ATTENTION! IMPORTANT SAFETY INFORMATION!

Follow the instructions on page 3 of this manual.

ES ¡ATENCIÓN! ¡INDICACIONES IMPORTANTES DE SEGURIDAD!

Deben seguirse las indicaciones detalladas en página 3 de estas instrucciones de montaje.

NL LET OP! BELANGRIJKE VEILIGHEIDSINSTRUCTIES!

Volg de instructies op pagina 3 van deze montagehandleiding op.

FR ATTENTION! IMPORTANTES INDICATIONS DE SÉCURITÉ!

Les instructions de la page 3 de cette notice de montage doivent être observées strictement.

IT ATTENZIONE! INDICAZIONI SULLA SICUREZZA IMPORTANTI!

Prestare attenzione alle note alla pagina 3 delle presenti istruzioni di montaggio.

DA PAS PÅ! VIGTIGE SIKKERHEDSANVISNINGER!

Oplysningerne på side 3 i denne monteringsvejledning skal følges.

DE ACHTUNG! WICHTIGE SICHERHEITSANWEISUNGEN!

Für die Sicherheit von Personen ist es wichtig, diesen Anweisungen Folge zu leisten. Diese Anweisungen sind aufzubewahren. Diese Anleitung finden Sie im Kundencenter unter <https://www.feig.de/login/>. Bitte loggen Sie sich mit folgenden Zugangsdaten ein. Benutzername: Download / Passwort: feig

EN ATTENTION! IMPORTANT SAFETY INFORMATION!

These instructions must be observed to ensure personal safety. Store these instructions safely. These instructions are available from the customer center at <https://www.feig.de/en/login/>. Please sign in with the following details: Username: Download / Passwort: feig

FR ATTENTION! IMPORTANTES INDICATIONS DE SÉCURITÉ!

Pour la sécurité des personnes, il est important de respecter les consignes en question. Les présentes consignes doivent être conservées en lieu sûr. Les instructions sont téléchargeables dans le centre de clientèle de <https://www.feig.de/en/login/>. Prière de vous logger avec les données suivantes. Username: Download / Passwort: feig

ES ¡ATENCIÓN! INDICACIONES IMPORTANTES DE SEGURIDAD

Para la seguridad de las personas es importante seguir estas indicaciones. Deben guardarse estas indicaciones. Puede encontrar estas instrucciones en el Centro de atención al cliente en <https://www.feig.de/en/login/>. Se ruega iniciar sesión con los siguientes datos de acceso: Username: Download / Passwort: feig

IT ATTENZIONE! INDICAZIONI SULLA SICUREZZA IMPORTANTI!

Per la sicurezza personale è importante attenersi scrupolosamente a queste indicazioni. Queste indicazioni vanno conservate. Le presenti istruzioni sono disponibili nell'area clienti del sito <https://www.feig.de/en/login/>. Effettuare il login con i seguenti dati d'accesso: Username: Download / Passwort: feig

NL LET OP! BELANGRIJKE VEILIGHEIDSINSTRUCTIES!

Voor de veiligheid van personen is het belangrijk om deze aanwijzingen op te volgen. Deze aanwijzingen dienen bewaard te worden. Deze handleiding kunt u vinden in het Customer Center op <https://www.feig.de/en/login/>. Gelieve de volgende toegangsgegevens te gebruiken. Username: Download / Passwort: feig

DA PAS PÅ! VIGTIGE SIKKERHEDSANVISNINGER

For sikkerheden af personer er det vigtigt at følge disse anvisninger. Disse anvisninger skal opbevares. Denne monteringsvejledning finder du i downloadområdet på <https://www.feig.de/en/login/>. Log på med følgende adgangsdata: Username: Download / Passwort: feig

FEIG ELECTRONIC

PRODUKTFINDER LOGIN EN f t x in

PRODUKTE BRANCHEN EVENTS **SERVIC** NEWS KARRIERE UNTERNEHMEN KONTAKT SUCHEN

HOME_LOGIN

KUNDENCENTER 1
EU-KONFORMITÄTSEKTLÄRUNG
RETOUREN

Benutzername: Download 2
Passwort: feig 2
Passwort vergessen?

3

USER LOGIN
Enter your user name and password to login to the website.
You do not yet have any login details
Register
Have you forgotten your login details?
Please send a mail to info@feig.de

BENUTZERANMELDUNG
Geben Sie Ihren Benutzernamen und Ihr Passwort ein, um sich an der Website anzumelden.
Sie haben noch keine Zugangsdaten
Registrieren Sie sich.
Sie haben Ihre Zugangsdaten vergessen?
Bitte senden Sie dazu eine Mail an info@feig.de

Contents

1	Legal Notice	7
1.1	Manufacturer	7
1.2	Scope	7
2	General information	8
2.1	Data protection and copy protection	8
2.2	Disclaimer of liability	8
2.3	Information on the document	9
2.4	Explanation of drawings	10
2.5	Technical terms	10
2.6	Abbreviations	11
3	Safety instructions	12
4	Proper use	13
5	Product overview	14
5.1	Scope of delivery	14
5.2	Accessories	14
5.3	Housing dimensions	15
5.4	Device components	16
5.5	Technical data	17
6	Product description	19
6.1	Product versions	19
6.2	Product characteristics	20
6.3	Product functions	20
6.3.1	Vehicle detection	21
6.3.2	Output signals	21
6.3.3	Alignment of the loop channels	21
6.3.4	Scanning of the loop channels	21
6.3.5	Loop error detection	21

7	Description of connections	22
7.1	Power supply.....	22
7.2	Loop inputs	22
7.3	Signal outputs	23
7.3.1	Relay outputs with changeover contact.....	23
7.3.2	Open collector outputs	23
8	Assembly and electrical installation	25
8.1	Assembly on the DIN rail TS35.....	25
8.2	Connecting the power supply	26
8.3	Connect the relay outputs (versions -R24).....	27
8.4	Connecting the open collector outputs (versions -O24)	27
8.5	Installing the induction loops.....	28
8.6	Connecting the induction loops.....	29
9	Commissioning	30
10	Description of functions	31
10.1	LED status indicators	31
10.2	DIP switch settings	32
10.2.1	DIP switch assignment of the MNH1 variants.....	33
10.2.2	DIP switch assignment of the MNH2 variants.....	34
10.3	Reset button	36
10.4	USB interface.....	36
10.5	<i>Detector Tool</i> service program	36
11	Description of settings	38
11.1	Adjusting sensitivity (switch-on threshold)	39
11.2	Setting hysteresis (switch-off threshold)	40
11.3	Setting loop frequency (frequency step)	41
11.4	Setting hold time	42
11.5	Setting output mode (signal type).....	42
11.6	Inverting the signal output (signal behaviour)	43
11.7	Behaviour in the event of loop error (error mode).....	43
11.8	Assigning an output to a loop (Assignment)	44
11.9	Setting output switching time (impulse time)	44

11.10	Setting output times (output time behaviour)	45
11.11	Setting direction detection (dual-channel variants)	46
11.12	Setting direction logic (dual-channel variants)	47
11.12.1	”Single vehicle” direction logic	48
11.12.2	”Queue” direction logic	49
11.12.3	”Wrong-way driver” 1 direction logic	49
11.12.4	”Wrong way driver 2” direction logic	50
11.12.5	”Manoeuvring” 1 direction logic	50
11.12.6	”Manoeuvring” 2 direction logic	51
11.12.7	”Wrong-way driver in queue” direction logic.....	52
11.12.8	Direction Logic „Cross traffic“	53
11.12.9	Direction Logic „Parking bay“	54
12	Maintenance & servicing	55
13	Decommissioning	55
14	Disposing of the product	55
15	Key words	56
16	Declaration of conformity	58

1 Legal Notice

1.1 Manufacturer

FEIG ELECTRONIC GmbH

Lange Straße 4

35781 Weilburg

Germany

Internet: www.feig.de

E-Mail: info@feig.de

Telephone: +49 (0) 6471 3109 – 0

1.2 Scope

Product type: Induction loop detector

Product name: VEK MNH

Fields of application: Traffic detector for traffic, barrier and door controller

Document type: Operating manual

Original language: German

Document language: English

Document Version: v1.4

Publication date: 23.11.2020

2 General information

2.1 Data protection and copy protection

Translations of the original document

All non-German versions of this document are translations of the original German Operating manual.

Validity of the document

These instructions are only valid for the version of the product specified.

This edition replaces all earlier versions of the documents.

The information in these instructions is subject to change without notice.

Copyright

Full or partial photocopying or reproduction of these instructions, as well as translation into other languages, is not permitted without the prior written consent of FEIG ELECTRONIC GmbH. The full or partial storage of these instructions on modern information carriers for the purpose of subsequent processing on computers is also prohibited.

2.2 Disclaimer of liability

FEIG ELECTRONIC GmbH does not provide any guarantee for the correctness and completeness of the specifications in these instructions. In particular, FEIG ELECTRONIC GmbH cannot be made liable for subsequent damage resulting from erroneous or incomplete information.

The information contained in this document has been compiled according to the best of our knowledge and belief. Despite all efforts, it is never possible to completely exclude incorrect information. We are always welcome information or enquiries.

The installation recommendations contained in this document assume favourable general conditions. FEIG ELECTRONIC GmbH does not provide any guarantee for the faultless function of the product in third-party environments.

FEIG ELECTRONIC GmbH does not provide any guarantee that the information in this document is free from third-party intellectual property rights. In issuing this document, FEIG ELECTRONIC GmbH does not issue any licenses for company or third-party patents or other property rights.

Only the direct contracting parties are entitled to place warranty claims against FEIG ELECTRONIC GmbH; they are non-transferable. Any warranty provided only applies to the products supplied by FEIG ELECTRONIC GmbH. We do not accept any liability for the complete system.

The description of the products, their deployment, capabilities and performance specifications will not be considered as assured properties and are subject to technical changes.

2.3 Information on the document

Read and keep instructions

Read this document before you use the product for the first time, and keep it in a safe place for future reference.

NOTE

Information in this document

This document refers to the default settings or default values defined by the manufacturer. The factory settings of customer variants may differ from the manufacturer's specifications. Please observe the instructions on the device, as well as the documents supplied with it.

This section explains the illustrations, instructions and information contained in this document.

⚠ CAUTION

Health hazard

Indicates risk of injury to persons and gives instructions on how to avoid and prevent them.

WARNING

Damage to property

Indicates possible damage to property and gives instructions for device safety and function.

NOTE

Useful information

Provides useful information on the composition and use of the device or document.

Prerequisites

Conditions for the steps

Indicates the prerequisites for carrying out the following instructions.

Tools

Resources for the steps

Indicates the tools required to carry out the following instructions.

Tip

Practical tips for application

Provides practical recommendations and examples.

2.4 Explanation of drawings



Refers to an important document or instruction which need to be read.



Outlines the specifications for product disposal

2.5 Technical terms

Technical term	Meaning
Switch-off threshold	Level of loop detuning until the output signal switches off
Induction loop detector	Sensor for detecting metallic objects by means of induction loops (coils)
Switch-on threshold	Level of loop detuning until the output signal switches on
Hysteresis	Difference in percent between the switch-on threshold and the switch-off threshold
LC oscillator	Electrical oscillatory circuit with coil and capacitor
Open collector	Bipolar transistor with internal blank collector output
Safety Extra-Low Voltage	Nominal voltage up to 50 VAC or 75 VDC and insulation against higher voltage for protection against electric shock (SELV)
Protection class III	Electrical safety protection class (see Safety Extra-Low Voltage)
Protection type IP	Protection type for environmental conditions (IP 20: protection against solid objects up to 12 mm, no protection against liquids)

Tab. 1: Explanation of technical terms

2.6 Abbreviations

Abbreviation	Meaning
CE	labelling to comply with the harmonisation legislation in accordance with EU regulation
COM	common terminal for relays with changeover contacts.
DIN	German industry standard
DIP	switch panel for default settings - Dual In-line Package
EMC	electromechanical compatibility
EN	European norm
GND	ground connection to power supply
IP 20	protection type of electrical equipment for environmental conditions and people
ISO	International Standards Organization
MNH	Traffic detectors series produced by FEIG ELECTRONIC GmbH
MR	machinery directive for the European Economic Area
NC	switch installed as opener (Normally Closed)
NO	switch installed as closer (Normally Open)
O24	product variants for 24 volts with open collector outputs (bipolar transistors)
OC	open collector connection
R24	product variants for 24 volts with relay outputs
RoHS	guidelines on pollution (Restriction of Hazardous Substances)
SELV	Safety Extra-Low Voltage
PLC	Programmable Logic Controller
UL	guideline for electrical safety (Underwriters Laboratories)
VAC	Volts of Alternating Current
VCC	Volts of Common Collector
VDC	Volts of Direct Current
VEK	sensor products made by FEIG ELECTRONIC GmbH
WEEE	directive on electrical waste (Waste Electrical and Electronic Equipment)

Tab. 2: Meaning of abbreviations

3 Safety instructions

Availability of documents

The Operating manual must be available at all times. The instructions must be read and understood before the device is used for the first time, and adhered to at all times.

Service only by trained electricians

All work on the device (assembly, connection, commissioning, decommissioning, maintenance, repair, measurements and settings) may only be carried out by qualified electricians with relevant training on the prevention of accidents.

Intended use

The device may only be used for the purpose intended by the manufacturer. Consult the chapter relating to intended use.

Improper use

The device is subject to the manufacturer's warranty conditions valid at the time of purchase. The manufacturer will not accept any responsibility for unsuitable or incorrect manual or automatic parameter settings performed on a device or the inappropriate use of a device.

Improper repairs

Repairs may only be performed by the manufacturer. Failure to comply will endanger the safety of the device and renders the warranty null and void.

Permitted voltages

The voltage supply must meet the requirements for safety extra-low voltage ("Circuits and power sources of limited power" SELV).

Regulations on electrical voltage

Users of devices which come into contact with electrical voltage must comply with the valid VDE regulations. These are in particular, but with no claim to completeness, VDE 0100, VDE 0550/0551, EN 60335 (VDE 0700), EN 60065 (VDE 0860), EN 50110 (VDE 0105), and the fire and accident-prevention regulations DGUV.

Comply with national regulations

All work on the device and its installation must be carried out in accordance with the specifications of the national electrical regulations and local regulations.

Essential safety equipment

The device may not be used as a safety component as defined by the Machinery Directive 2006/42/EG, the Construction Products Regulation 305/2011/EU or other safety regulations. Systems with a hazard potential require additional safety equipment!

4 Proper use

Induction loop detectors such as traffic detectors are operated in combination with various induction loops and electronic controller, such as frequency converters and PLC controller.

Areas of application are systems in the areas of traffic engineering, door and barrier controller, parking and tunnel monitoring as well as traffic light systems.

The traffic detectors of the VEK MNH series are intended for installation in a controller cabinet or a similar housing.

WARNING

Comply with the technical data

The detector may only be operated with the prescribed supply voltages. Take note of the technical data before installation.

WARNING

Protection from environmental influences

The device must be installed in a location where it will not sustain damage from heat, dripping water, moisture or dust.

Incorrect use

Alterations to the device and the use of spare parts and additional devices not sold or recommended by the manufacturer of the device may result in injuries and damage resulting from electric shocks and fires. Such actions result in a disclaimer of liability and forfeiture of the warranty.

Impermissible interference with the housing

Do not open the housing. This poses a danger to persons and the device functions and result in a disclaimer of liability and forfeiture of the warranty.

5 Product overview

5.1 Scope of delivery

Product	Traffic detector VEK MNH
Accessories	Plug-in terminal blocks: 1x power supply, 1x loops, 2x relays or 2x open collector
Document	Operating manual

Tab. 3: Scope of delivery

Downloads
Short description (multiple languages, as download under www.feig.de)
Operating instructions (multiple languages, as download under www.feig.de)
<i>Detector Tool</i> service program (multiple languages, as download under www.feig.de)
<i>Detector Tool</i> instruction manual (multiple languages, as download under www.feig.de)

Tab. 4: Download of product accessories

5.2 Accessories

Item no.	Designation	Description
4405	VEK USB cable	2.0 m USB cable type A to mini AB

Tab. 5: separately available accessories

5.3 Housing dimensions

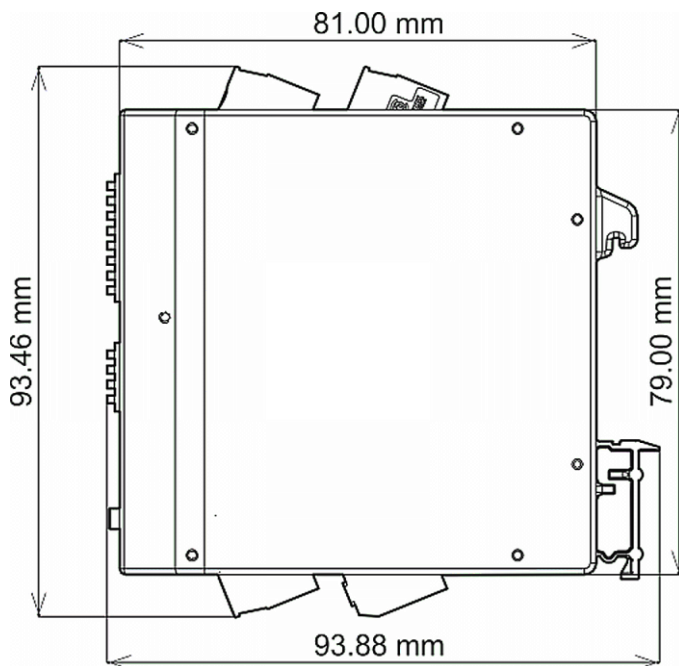

Fig. 1: VEK MNH2 side view

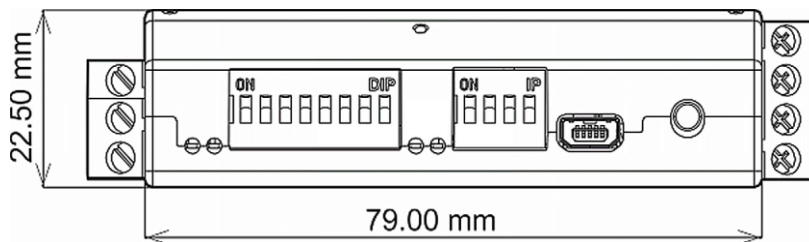

Fig. 2: VEK MNH2 front view

5.4 Device components

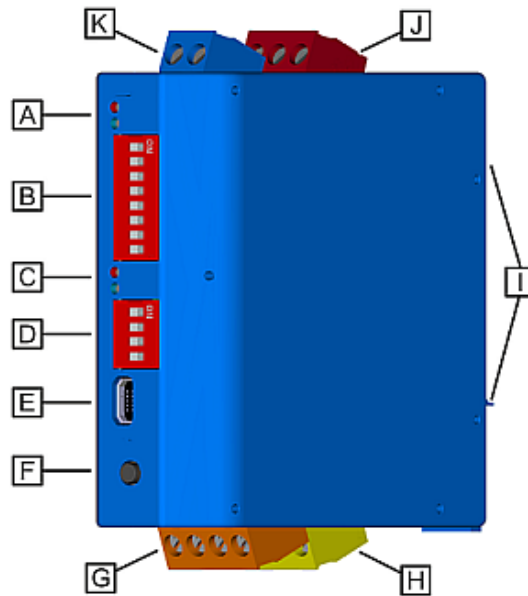

Fig. 3: Traffic detector VEK MNH

Index	Component	Description
A	Loop channel LEDs 1 (red + blue)	Status indicators for the loops and the detector
B	DIP switch 1	Basic settings for the detector
C	Loop channel LEDs 2 (red + blue)	Status indicators for the loops and the detector
D	DIP switch 2 (MNH2 variant)	Basic settings for the detector
E	USB connection	PC interface for configuration and diagnostics
F	Reset button	Factory settings or fresh adjustment
G	Loop inputs (orange)	Connections for induction loops
H	Output 1 terminal block: <ul style="list-style-type: none"> Relay output 1 (yellow, R24 variant) Open collector output 1 (green, O24 variant) 	Signal outputs for controller
I	Mounting bracket	Mounting device for TS35 DIN rail
J	Output 2 terminal block: <ul style="list-style-type: none"> Relay output 2 (red, R24 variant) Open collector output 2 (green, O24 variant) 	Signal outputs for controller
K	AC/DC connection (blue)	Connections for power supply

Tab. 6: VEK MNH Traffic Detector

5.5 Technical data

Specifications	
Housing	Plastic housing, ABS, blue
Mounting method	TS35 DIN rail
Dimensions	22.5 x 79.0 x 81.0 mm (W x H x L, without terminals)
Power supply (1 x blue)	2-pole terminal block (see Note 3) 10 – 30 VDC / 10 – 26 VAC (SELV) <ul style="list-style-type: none"> • R24 variants: max. 2 W • O24 variants: max. 1 W
Power consumption	Typically 500 mW
Protection class	III
Protection type	IP20
Environmental conditions	
• permitted operating temperature	-37 – +70 °C
• permissible storage temperature	-40 – +85 °C
• relative humidity	< 95 % (non-condensing)
Loop properties	
• max. inductivity range	20 - 700 μ H (see note 1)
• recommended inductivity range	100 – 300 μ H
• operating frequency	30 – 130 kHz
• cable length	200 m
• internal resistance	20 Ω (including cable)
• min. insulation resistance to earth	100 k Ω (constant, including cable)
• insulation voltage, loop inputs	1 kV (galvanic isolation)
Cycle and reaction time	12 ms (independent of loop channels)
Maximum speed for vehicles	
• presence detection	Max. 200 km/h
• direction detection (dual-channel variants)	Max. 200 km/h (at loop head distance of 2 m)

Specifications	
Inputs	
• 1 x loop (1 x orange, single-channel variants)	2-pole terminal block (see Note 3)
• 2 x loop (1 x orange, dual-channel variants)	4-pole terminal block (see Note 3)
Outputs	
• 2 x relays (1 x yellow, 1 x red, R24 variants)	3-pole terminal block (see Note 3) Max. 48 V (AC/DC), 2 A, 60 W, 125 VA (SELV) Min. 1 mA / 5 V (see note 2)
• 4 x open collector (2 x green, O24 variants)	3-pole terminal block (see Note 3) 27 V DC, 25 mA (SELV)
Configuration switch 1 (all variants)	8-pole DIP switch
Configuration switch 2 (dual-channel variants)	4-pole DIP switch
LED status indicator	1 x blue and 1 x red (per loop channel)
Reset button	Push button
PC interface	USB port, type mini AB

Tab. 7: Specifications

NOTE

1) Limitations on loop inductance

For loop inductances outside the recommended range, only one frequency level may be available. For very small loop inductances, the maximum loop resistances are lower.

2) Current load of the relay contacts

The rigid gold plating on the relay contacts will be destroyed if the switching current exceeds 100 mA. Relays with contacts that are prestressed in this manner can only reliably switch currents over 100 mA!

3) Terminal block data

Grid dimension 5.0 mm, conductor cross-section 0.25 - 2.5 mm², AWG 24-12

6 Product description

Induction loop detectors such as traffic detectors are electronic sensors for inductive detection of metallic objects. Using induction loops, for example, vehicles are detected, and depending on the device, their design and direction of movement.

The traffic detectors are operated in combination with various induction loops and electronic controller, such as frequency converters or PLC controller.

The areas of application are, for example, the detection, monitoring and counting of vehicles in the areas of traffic engineering, door and barrier controller, parking and tunnel monitoring as well as traffic light systems.

6.1 Product versions

The Traffic detector is available in the following versions:

Product name	Features
VEK MNH1-R24-A	<ul style="list-style-type: none"> • 1 Channel for one induction loop • 2 Relay outputs • 8-pole DIP switch for configuration • USB diagnostic interface • Reset button • 24 V supply voltage • Top hat rail mounting • Plastic housing
VEK MNH2-R24-C	<ul style="list-style-type: none"> • 2 Channels for two induction loops • 2 Relay outputs • 8-pole DIP switch for configuration • 4-pole DIP switch for configuration • USB diagnostic interface • Reset button • 24 V supply voltage • Top hat rail mounting • Plastic housing
VEK MNH2-O24-D	<ul style="list-style-type: none"> • 2 Channels for two induction loops • 4 Open collector outputs • 8-pole DIP switch for configuration • 4-pole DIP switch for configuration • USB diagnostic interface • Reset button • 24 V supply voltage • Top hat rail mounting • Plastic housing

Tab. 8: Product versions

NOTE

Systems with high switching frequency

The use of detectors with digital outputs is recommended for systems with a high switching frequency. A restricted switching cycle limits the operational life of relay contacts.

6.2 Product characteristics

The traffic detectors have the following properties:

- 1 loop channel (single-channel variants) or 2 loop channels (dual-channel variants)
- 2 potential-free relay outputs with changeover contact (R24 variants)
- 4 open collector outputs (O24 variants)
- 8-pole DIP switch for configuration
- 4-pole DIP switch for advanced configuration
- 2 or 4 LEDs for the indication of detector and loop states
- USB interface for diagnostics and advanced configuration
- Connection for power supply (AC/DC)
- Galvanic isolation between loops and electronics
- Automatic adjustment of the device after switch-on
- Continuous adjustment of frequency drifts to suppress environmental influences
- Sensitivity independent of loop inductance
- Fixed hold times regardless of the loop coverage
- Direction detection based on two loop channels (dual-channel variants)
- Multiplexing prevents mutual interferences of the loop channels (dual-channel variants)
- Compact plastic housing for mounting on DIN rail in control cabinet

6.3 Product functions

The traffic detectors offer the following setting options:

- Switching between two frequency levels
- Output as presence or pulse signal or of loop faults (with *Detector Tool*)
- Response threshold adjustable in 255 steps with *Detector Tool*, in 4 steps with DIP switch
- Hold time adjustable from 1 to 255 minutes and infinite with *Detector Tool*, 5 minutes or infinite with DIP switch
- Counter for loop occupation and travel direction with *Detector Tool*
- Minimum signal duration for output signal with *Detector Tool*
- Switch-in and switch-off delay adjustable with *Detector Tool*
- Hysteresis (drop in threshold value) adjustable from 20 - 80% on each channel with *Detector Tool*
- Detector channels can be switched off with *Detector Tool*
- Comprehensive diagnostic function with *Detector Tool*

Advanced functions of the dual-channel variants:

- Output as presence, pulse or direction signal (dual-channel variant) or loop faults (with *Detector Tool*)
- Selection of direction logic

6.3.1 Vehicle detection

Whether a metallic object is located in the loop area is identified via an LC oscillator (electrical oscillatory circuit). The channel output is switched according to the output function configured.

6.3.2 Output signals

Depending on the output configuration, presence, pulse or direction signals and direction logics (VEK MNH2) as well as loop faults are output.

For the pulse signal, it is also possible to select whether an output should occur when a loop is driven past or vacated.

In addition to inversion of the output signal, both outputs can individually be permanently switched on or off.

6.3.3 Alignment of the loop channels

When the detector is switched on or the reset button on the front is pressed for one second, an alignment of the loop channels is run.

If there has been an interruption of power, an automatic alignment only takes place if the operating voltage has been interrupted for at least 0.5 seconds. Alignment takes around one second if no vehicles drive over the loop in this time.

External influences on the loop frequency may result in longer alignment times, and their causes must be determined and eliminated.

6.3.4 Scanning of the loop channels

The dual-channel traffic detector can evaluate two loop channels.

The timed scanning of the loops is carried out in multiplex mode. They are connected to the common oscillatory circuit oscillator over a multiplexer. This prevents the loops interfering with each other.

The connected induction loops are switched on and off in rapid succession. Current is only ever supplied to one loop at a time. This means that both loops can be operated at the same frequency.

The cycle time of a scan in multiplex mode is 12 ms.

6.3.5 Loop error detection

Loop closure and *loop break* are identified as loop errors.

If no induction loop is connected to the loop channel, this corresponds to a *loop break* error status.

Once a loop error has been detected, the loop channel switches off. This may cause the available operating modes to be restricted, for example direction detection.

When one loop channel is switched off by the *Detector Tool*, this does not affect the second, connected loop channel (2 channel versions).

7 Description of connections

In the following section, the connections for the inputs and outputs are described.

7.1 Power supply

The detector can be operated with direct or alternating current, according to the requirements for Safety Extra-Low Voltages (SELV) of Protection Class III.

WARNING

Note the permitted power supply

Comply with the technical data and safety instructions!

The power supply is connected to the blue terminal block.



Fig. 4: Power supply connection (blue)

7.2 Loop inputs

Up to two analogue inputs for the induction loops on the terminal block are located on the underside of the traffic detector. The terminal block is either 2-pole or 4-pole, depending on the product variant.

The induction loops are connected to the orange terminal blocks as shown in the illustration.

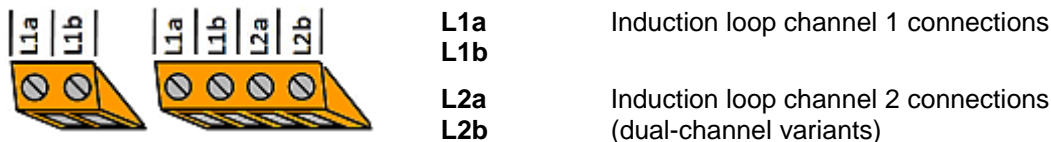

Fig. 5: Loop connections (orange)

7.3 Signal outputs

VEK MNH series detectors are available in variants with relay outputs (R24) and with open collector bipolar transistors (O24).

The relay variants are intended particularly for situations which require mechanical switches with high power outputs.













The open collector outputs are primarily intended for applications with high switching rates and low output power, e.g. PLC controller.

7.3.1 Relay outputs with changeover contact

The relays are designed as changeover contacts. Thus the outputs can be connected as normally closed (NC) or as normally open (NO). The relays are potential-free and suitable for many different types of switching modes.

All signal outputs can be inverted. In this case, when the power supply is turned on, normally open contacts function as normally closed contacts, and vice versa. This happens by switching between open-circuit and closed-circuit principle.

Loop malfunctions can also be interpreted as *loop covered* or as *loop free*.

Status	Normally closed contact (NC)		Normally open contact (NO)	
	Not inverted (open-circuit principle)	Inverted (closed-circuit principle)	Not inverted (open-circuit principle)	Inverted (closed-circuit principle)
Power supply off				
Detector ready, loop free				
Loop covered				
Loop malfunction	(by default: <i>loop covered</i> ; configurable as <i>loop free</i> with <i>Detector Tool</i>)			

Tab. 9: Switching states of the signal outputs

The analogue outputs of the relay variants (R24) are connected to the red and yellow terminal blocks according to the following illustration.

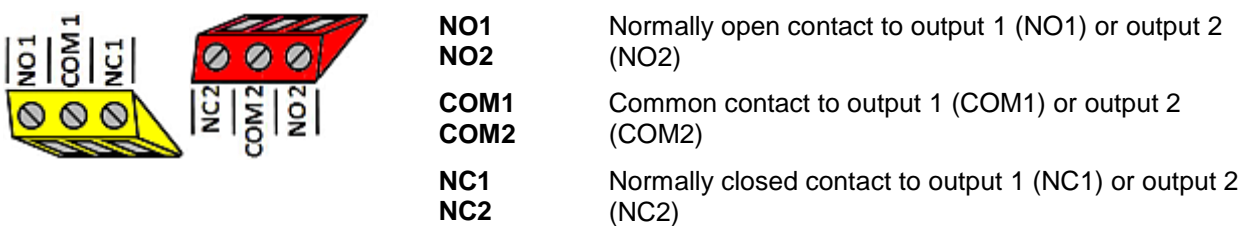

Fig. 6: Relay connections 1 (yellow) and 2 (red)

7.3.2 Open collector outputs

The Open Collector variant (O24) has four Open Collector outputs as digital switches for external operating supplies (V_{bb}). For each loop channel one output for the state of coverage (object detection) and one output for malfunctions (fault messages) are provided.

Depending on the configuration, the outputs switch to high or low impedance (GND_{OC}). The switching logic is set via the DIP switches or the *Detector Tool* software (fault messages only with *Detector Tool*). The outputs are inverted by default.

Status	Object detection Outputs OC1, OC2		Fault messages Outputs OC3, OC4	
	Not inverted	Inverted	Not inverted	Inverted
Power supply off	High impedance	High impedance	High impedance	High impedance
Detector ready, loop free	High impedance	GND OC	High impedance	GND OC
Loop covered	GNDoc	High impedance	High impedance	GNDoc
Loop malfunction	(by default: <i>loop covered</i> , configurable as <i>loop free with Detector Tool</i>)		GND OC	High impedance

Tab. 10: Switching states of the signal outputs

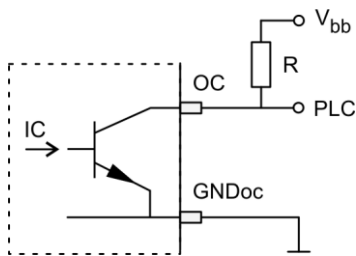

Fig. 7: Open Collector wiring diagram

Label	Description
OC	Open Collector connection
GNDoc	Reference ground connection (GNDoc < 1 VDC)
IC	Digital integrated circuit
Vbb	External working supply ($V_{bb} \leq 27$ VDC)
R	External Pull-up resistor
PLC	Connection of a controller (for example PLC)

Tab. 11: Open Collector description

The digital outputs of the Open Collector variants (O24) are connected to the green terminal blocks according to the following illustration.

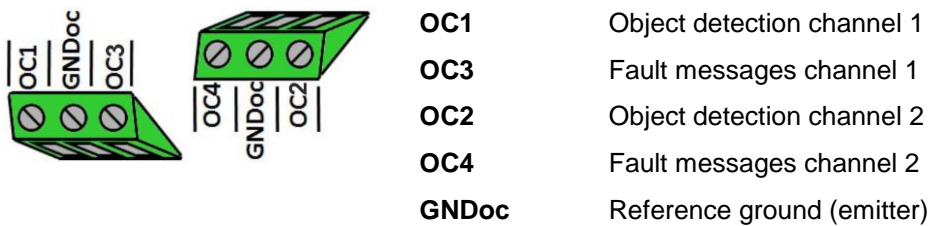

Fig. 8: Open Collector connections 1/ 3 and 2/ 4 (green)

8 Assembly and electrical installation

In the following section, assembly and electrical installation are described.

NOTE

Illustrations and technical data on the device

You can find illustrations and technical data on the housing and connections in the sections at the beginning of this document.

8.1 Assembly on the DIN rail TS35

Prerequisites

Assembly conditions

Tools: none

Mounting device: DIN rail TS35 (top hat rail)

Fixing to the top hat rail

1. Place on the device from above with the groove on the top hat rail and lock the clip underneath.
2. Check that it is sitting securely.
 - The detector is ready for commissioning.

8.2 Connecting the power supply

WARNING

Maintain the permitted voltages

The following voltage supplies are permitted:

- 10 - 30 VDC
- 10 - 26 VAC

Consult the chapter *Description of connections*.

PREREQUISITES

Connect the inputs and outputs with no voltage present

All inputs and outputs must be connected before switching on the voltage supply.

TOOLS

- Insulated flat-head screwdriver (width: 2 – 3 mm)

Connecting the power cable

1. Follow the warning and safety instructions and take the appropriate precautions.
2. If necessary, pull the terminal block out of the socket.
3. Loosen the screws on the blue terminal block.
4. Insert up to 5 mm of stripped supply cable into the slots at the side of the blue terminal block and fix.
5. Tighten the respective screw.
6. If necessary, insert the terminal block back into the blue 2-pole socket.
 - The supply cable is firmly attached to the terminal block with no exposed wires.

Connect the power cable to the power source

1. Comply with the warnings and safety instructions for the external device.
2. Follow the manufacturer's instructions on wiring the outputs on the external device.
 - The power cable is connected to the power source.

8.3 Connect the relay outputs (versions -R24)

TOOLS

Insulated slotted screwdriver (width 2 – 3 mm)

Connecting the relay outputs

1. Follow the warning and safety instructions and take the appropriate precautions.
2. If necessary, pull the red or yellow terminal block out of the socket.
3. Loosen the screws on the blue terminal block.
4. Insert up to 5 mm of stripped cable into the slot on the side of the terminal block and fasten.
5. Tighten the screw.
6. If necessary, insert the terminal block back into the red or yellow 3-pole socket.
 - The cables of the relay outputs are firmly attached to the terminal block with no exposed wires.

Connect the relay cable to the external device

1. Comply with the warning and safety instructions for the external device.
2. Follow the manufacturer's instructions on wiring the outputs on the external device.
 - The relay outputs are connected to the signal outputs on the external device.

8.4 Connecting the open collector outputs (versions -O24)

TOOLS

Insulated slotted screwdriver (width: 2 – 3 mm)

Connecting the open collector outputs

1. Follow the warning and safety instructions and take the appropriate precautions.
2. If necessary, pull the green terminal block out of the socket.
3. Loosen the screws on the blue terminal block.
4. Insert up to 5 mm of stripped cable into the slot on the side of the terminal block and fasten.
5. Tighten the screw.
6. If necessary, insert the terminal block back into the green 3-pole socket.
 - The cables of the open collector outputs are firmly attached with no exposed wires.

Connecting the external device

1. Comply with the warning and safety instructions for the external device.
2. Follow the manufacturer's instructions on wiring the outputs on the external device.
 - The relay outputs are connected to the signal outputs on the external device.

8.5 Installing the induction loops

- The induction loops must be installed with a clearance of min. 15 cm to fixed metal objects and 1 m to mobile metal objects. The clearance to the surface of the final road surface should not amount to more than 5 cm.
- It is vital that the loop cable is installed separately from the supply lines
- A normal single pole cable with a cross section of 1.5 mm² must be used as a loop cable.
- If buried in the ground, the cable must be equipped with suitable insulation. If you use hot sealing compound, make sure the cable has a suitable temperature stability.
- Induction loops should preferably be realised in squares or at right angles. If it is not possible to use finished loops, they should be installed in a groove cut in the road surface as shown in the figure below. The loop cable must be fixed well in the groove. Then fill the groove with sealing compound. The corners should have a 45° angle to avoid damage to the cable insulation.

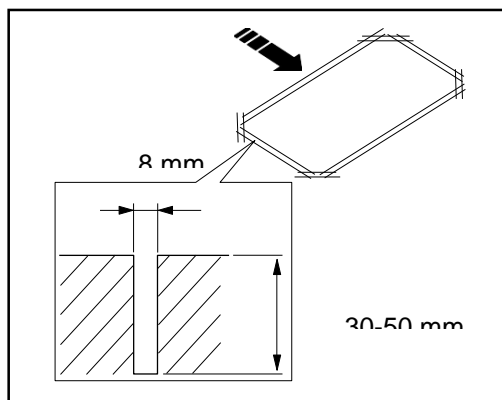

Fig. 9: Installing the loops

- When installing the cable, comply with the number of turns specified in the table.

Scope of the induction loop	Number of turns
Smaller than 3 m	6
3 - 4 m	5
4 - 6 m	4
6 -12 m	3
Larger than 12 m	2

Tab. 12: Number of turns on the loop cable

- The two cable ends leading from the induction loop to the detector (loop supply line) must be twisted with min. 20 strokes/m.
- Avoid dividing the cable. Should it be necessary to divide the cable, protect the clamp points against moisture penetration with cast resin collars.

8.6 Connecting the induction loops

RECOMMENDATIONS

The requirements for the induction loops differ according to the area of application. Allow the supplier to advise you on installation of the induction loops.

PREREQUISITES

The induction loops are already installed and ready for use.

TOOLS

- Insulated slotted screwdriver (width: 2 – 3 mm)
 - Induction loops for the respective area of application
-

Connecting the induction loops

1. Follow the warning and safety instructions and take the appropriate precautions.
2. If necessary, pull the orange terminal block out of the socket.
3. Loosen the screws on the blue terminal block.
4. Insert up to 5 mm of stripped cable into the slot on the side of the terminal block and fasten.
5. Tighten the screw.
6. If necessary, insert the terminal block back into the orange 4-pole socket.
 - The induction loops are firmly attached with no exposed wires.

9 Commissioning

Prerequisites

Assembly and electrical connection

- The system is not in use.
 - All work must be carried out by qualified specialist personnel.
 - All available cables are firmly attached to the terminal block.
 - The terminal blocks are sited on the input and output sockets of the same colour.
 - The detector is firmly mounted on the top hat rail.
-

Tools

Tools for the system

Always comply with the manufacturer's instructions!

No tools are required to commission the system.

Commissioning the detector

1. Define the settings with the DIP switches.
2. Switch on the power supply to the detector.
 - The VEK MNH series detectors automatically run a test of the induction loops as well as a frequency alignment.
 - The detector is ready for operation when the blue LEDs are continuously lit. There is more information in the chapter on LED indicators.
3. Start up all components of the system (comply with the manufacturer's instructions).
4. Carry out a functional test of the system (comply with the manufacturer's instructions).
 - The detector is ready for continuous operation.

NOTE

Optimising the detector settings

The device settings can be changed using the DIP switch while it is operating.

The detector can be analysed and optimised via the USB interface.

Further information is provided in the chapter about the DIP switch and the *Detector Tool*.

10 Description of functions

In the following section the indicator and control elements are described.

NOTE

Information in this document

This document refers to the default settings or default values defined by the manufacturer. The factory settings of customer variants may differ from the manufacturer's specifications. Please observe the instructions on the device, as well as the documents supplied with it.

10.1 LED status indicators

The LEDs (light emitting diodes) on the front side indicate the state of the loops and the detector.

There are two LEDs for each loop channel:

- The red LED indicates the coverage status of the respective loop
- The blue LED indicates the operating status of the detector

Red LED	Blue LED	Description of status
		No power supply, detector inactive
		Detector ready, loop connected, no object detected
		Detector ready, loop connected, object detected
		No loop connected, loop break, loop closure
	 1 Hz	Ready for operation following earlier, now rectified, loop error or settings changed with <i>Detector Tool</i> (DIP switch not up-to-date)
	 5 Hz	Frequency alignment is running
 	 	After frequency adjustment, both LEDs simultaneously display the set loop frequency in a flash code (see <i>Flash code</i> illustrated example)

Tab. 13: LED signal colours

Key to LED symbols

- Lit up
- Off
- Flashing
- Frequency

LED flash code following a frequency alignment

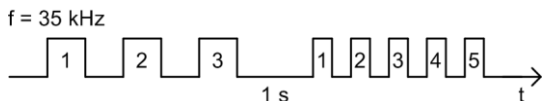

Fig. 10: LED display of loop frequency

NOTE

LED position

The LEDs for the loop channel 1 are located at the top or side of the device, for loop channel 2 are in the middle.

10.2 DIP switch settings

NOTE

Further information

- You can find detailed information on settings options in the section *Description of settings*.
- The *Detector Tool* service program offers further settings options. For information on these, read the section on the *Detector Tool*.
- If the settings are changed with the *Detector Tool*, the DIP switch settings are no longer valid. This will be indicated by the blue LEDs flashing. Also read the section on the Reset button.

Function	Description
Sensitivity	Switch-on threshold for signal output when the loop is covered
Frequency level	Frequency of the loop resonant circuit in two levels
Hold Time until readjustment	Maximum duration of the output signal until automatic frequency adjustment of the loop channel
Output signal 2 mode	Switching between continuous signal and pulse signal at output 2
Time of output signal 2	Time of output signal for activated pulse signal on output 2
Output signal inversion	Reversing the switching logic for the output signals (inversion)
Direction detection	Switching between presence and direction detection for both outputs (2 channel variants)
Direction logic	Evaluation logic of the direction of travel when loop is covered according to the specific application (read the operating instructions!)

Tab. 14: Description of the settings

10.2.1 DIP switch assignment of the MNH1 variants

The single-channel variants have an 8-pole DIP switch for configuring the detector.

DIP	Designation	Function
1	Sense a	Loop 1 sensitivity
2	Sense b	Loop 1 sensitivity
3	Frequency	Frequency step
4	Hold time	Hold time until readjustment
5	Output 2	Output signal 2 mode
6	Edge 2	Output signal 2 time
7	Inv. Out 1	Output signal 1 inversion
8	Inv. Out 2	Output signal 2 inversion

Tab. 15: DIP switch assignment (default)

The following parameters can be adjusted with the DIP switch:

DIP switch	Position	Value
Sense a	ON	0.01% (high)
Sense b	ON	
Sense a	OFF	0,04%
Sense b	ON	
Sense a	ON	0,16%
Sense b	OFF	
Sense a	OFF	0.64% (low)
Sense b	OFF	
Frequency	OFF	low
	ON	high
Hold time	OFF	5 minutes
	ON	Infinite
Output 2	OFF	Pulse signal
	ON	Continuous signal
Edge 2	OFF	on entering
	ON	on leaving
Inv. Out 1	OFF	Output inverted
	ON	Output not inverted
Inv. Out 2	OFF	Output not inverted
	ON	Output inverted

Tab. 16: Settings via DIP switch (single-channel)

10.2.2 DIP switch assignment of the MNH2 variants

The 2 channel versions have an 8-pole and 4-pole DIP switch for configuring the detector.

DIP1	Label	Function
1	Sense 1a	Loop 1 sensitivity
2	Sense 1b	Loop 1 sensitivity
3	Sense 2a	Loop 2 sensitivity
4	Sense 2b	Loop 2 sensitivity
5	Frequency	Frequency level
6	Hold time	Hold time until readjustment
7	Output 2	Output signal 2 mode
8	Edge 2	Time output signal 2

Tab. 17: DIP switch 1 occupancy (standard)

DIP2	Label	Function
1	Dir. Mode	Direction detection
2	Dir. Logic	Direction logic
3	Inv. Out 1	Output signal 1 inversion
4	Inv. Out 2	Output signal 2 inversion

Tab. 18: DIP switch 2 occupancy (standard)

The following parameters can be adjusted with the DIP switch:

DIP switch	Position	Value
Sense 1a / 2a	ON	0.01% (high)
Sense 1b / 2b	ON	
Sense 1a / 2a	OFF	0,04%
Sense 1b / 2b	ON	
Sense 1a / 2a	ON	0,16%
Sense 1b / 2b	OFF	
Sense 1a / 2a	OFF	0.64% (low)
Sense 1b / 2b	OFF	
Frequency	OFF	low
	ON	high
Hold time	OFF	5 minutes
	ON	Infinite
Output 2	OFF	Continuous signal
	ON	Pulse signal
Edge 2	OFF	on entering
	ON	on leaving
Inv. Out 1	OFF	Output inverted
	ON	Output not inverted
Inv. Out 2	OFF	Output not inverted
	ON	Output inverted
Dir. Mode	OFF	Presence
	ON	Direction
Dir. Logic	OFF	Continuous signal 2
	ON	Wrong-way driver 1

Tab. 19: Settings via DIP switch (dual-channel)

10.3 Reset button

The device is reset using the reset button on the front as follows:

Function	Description	Press button	LED
Reset / Readjustment	Runs a frequency readjustment and clears the LED fault messages	1 second	Red LED flashes
Factory settings	Resets the device to factory settings (DIP switch default settings)	5 seconds	Blue LED flashes

Tab. 20: Reset functions

10.4 USB interface

Detailed configuration and diagnosis of the detector data are possible via the USB interface.

The free *Detector Tool* service program can be downloaded from the customer area at www.feig.de. In addition, a computer and a USB cable of the Mini-AB type are required.

10.5 *Detector Tool* service program

NOTE

Registered users may download the *Detector Tool* free of charge from the download area under www.feig.de.

You can find detailed information on the diagnostic functions and advanced configuration options in the guide to the *Detector Tool*. The guide is also available in the download area.

NOTE

Overwriting the DIP switch

Changes made with the *Detector Tool* overwrite the DIP switch settings. When this happens, the blue LEDs flash continuously. In this case, the DIP switch positions may no longer be valid. Pressing the reset button for 5 seconds resets to the factory settings and clears the LEDs (see section *Reset button*).

Configuring the detector

The *Detector Tool* offers additional settings and parameters for configuring the device on top of those offered by the DIP switches. These include, for example, loop sensitivity, hysteresis (drop in threshold value), hold time, behaviour in the event of loop errors, output signal functions, direction detection and switch-on or switch-off delay on the relays.

Diagnostic data indicator

You can evaluate the current diagnostic data with the *Detector Tool*. These include, for example, loop frequency, detuning of the induction loops and their chronological sequences, the current status of the loops, the last maximum retuning, the coverage duration, the period between two coverages, the elapsed hold time, the status of the relays, and the travel direction detected.

The following illustration shows the process of loop detuning by vehicles.

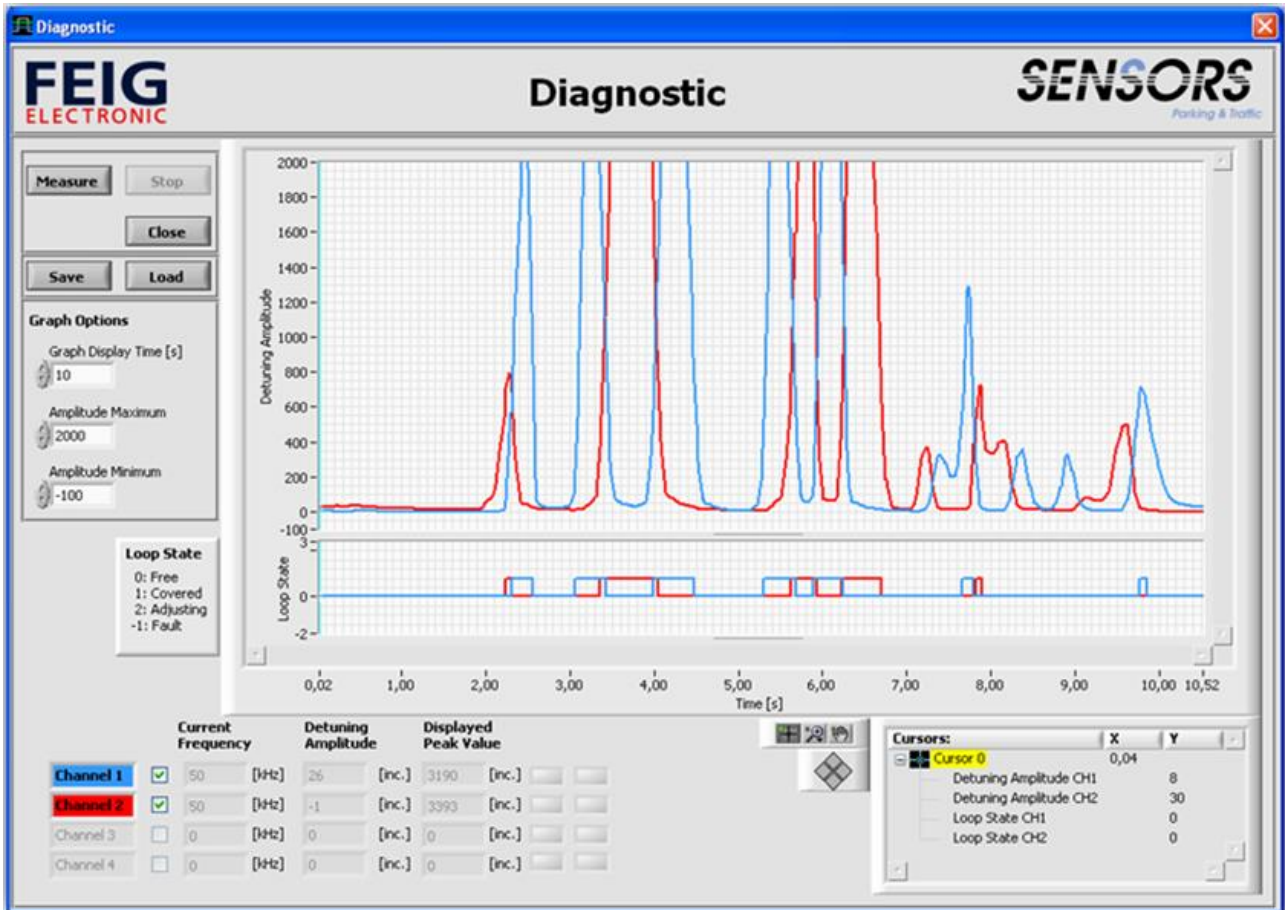

Fig. 11: Detector tool diagnostic view

11 Description of settings

The functions described below can be performed with the *Detector Tool* service program as well as with the DIP switch. The DIP switch provides the key default settings. Commissioning is not possible without the service program.

NOTE

- You can run diagnostics and perform further settings with the *Detector Tool*.
- If the settings are changed with the *Detector Tool*, the blue LEDs flash continuously.
- In order to reset to factory settings, hold the reset button down for 5 seconds.

Key to tables	
()	Printed designations of the default versions and designations provided in the <i>Detector Tool</i> are shown in brackets.
DIP	Information in this column shows the settings options for the DIP switch.
Detector Tool	Information in this column shows the settings available in the <i>Detector Tool</i> .

NOTE

Information in this document

This document refers to the default settings or default values defined by the manufacturer. The factory settings of customer variants may differ from the manufacturer's specifications. Please observe the instructions on the device, as well as the documents supplied with it.

11.1 Adjusting sensitivity (switch-on threshold)

The switch-on threshold can be selected in 255 increments in the range between 0.01% and 2.55% $\Delta f/f$. The higher the switch-on threshold, the lower is the sensitivity for signal activation.

Typical settings

- Generally speaking, sensitivity is adjusted in large steps, and the switch-on threshold selected is not greater than 640.
- Switch-on thresholds of over 640 and fine tuning may not be required for differentiation between vehicles. It is possible to differentiate, for example, buses with large loops (e.g. 10.0 m x 2.5 m) and correspondingly high threshold values (>1000).

NOTE

Minimising interference factors

In order to minimise interference factors, the sensitivity should be as low as possible, i.e. the value of the switch-on threshold should be as high as possible.

DIP (Sense a)	DIP (Sense b)	Detector Tool (switch-on threshold)	Sensitivity ($\Delta f/f$)
ON	ON	10	0.01 % Level high (highest sensitivity)
		20	0.02%
		30	0.03%
OFF	ON	40	0.04% Level medium-high
		50	0.05%
	
		150	0.15%
ON	OFF	160	0.16% Level medium-low
		170	0.17%
	
		630	0.63%
OFF	OFF	640	0.64% level medium-low (factory setting)
		650	0.65%
	
		1000	1.00%
	
		2550	2.55% Level minimum (lowest sensitivity)

Tab. 21: Sensitivity settings

11.2 Setting hysteresis (switch-off threshold)

In order to prevent any intermittent cut-out in the coverage signal in the case of vehicles with high substructures such as articulated buses, trams or HGVs with trailers, it is possible to change the switching hysteresis (switch-off threshold). Interruption-free detection of critical vehicles is then also possible at a lower sensitivity.

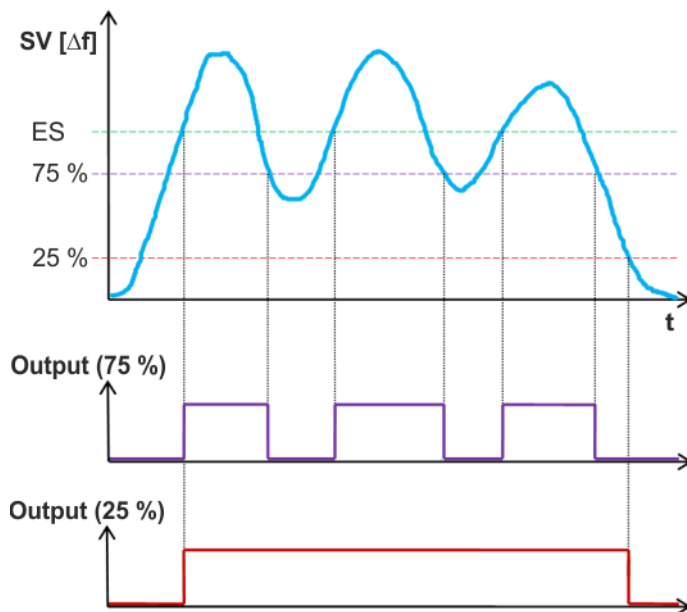

Fig. 12: Switch-off threshold hysteresis

Symbol	Description
SV (Δf)	Loop detuning by vehicle
ES	Switch-on threshold (reference value 100 %)
75 %	Switch-off threshold at 75 % of the switch-on threshold
25 %	Switch-off threshold at 25 % of the switch-on threshold
Output (...)	Signal output at 75 % or 25 % hysteresis
t	Duration

Tab. 22: Key to symbols

NOTE

Setting the hysteresis

The hysteresis is set in the *Detector Tool*.

DIP	Detector Tool (hysteresis)	Switch-off threshold (hysteresis in % of the switch-on threshold)
	20 %	minimal (low switch-off threshold)

	75 %	(factory setting)

	80 %	maximum (high switch-off threshold)

Tab. 23: Hysteresis settings

Switch-off threshold indicator

In the *Detector Tool*, the switch-off threshold is displayed as a multiplication of the hysteresis (%) with the switch-on threshold (absolute value). The absolute value of the switch-off threshold thus changes analogously to the hysteresis.

Examples

In the case of a switch-on threshold of 160 and varying hystereses, the switch-off threshold is calculated as follows:

Hysteresis 75% → cut-out threshold value: 0.75 160 120

Hysteresis 20 % → cut-out threshold value: 0.20 160 32

11.3 Setting loop frequency (frequency step)

The operating frequency setting serves to prevent couplings.

Interference between loops

Couplings may occur between adjacent loops or loop connections from other detectors. Therefore, loops less than 2 metres apart should not operate at the same loop frequency. In this case a frequency spacing of at least 5 kHz must be maintained.

Loop frequency indicator

The operating frequency of the loops after switching on or changes is reflected with an LED flash sequence and can be read off in the *Detector Tool*.

Multiplexing

No coupling between the loops of a detector takes place through multiplexing (2 channel version). The loops on a detector may therefore operate on the same frequency.

WARNING

Deactivating free loop channels

Loop channels with no permanently connected induction loops should be switched off in the *Detector Tool*. If this is not done, a cyclical request is made asking whether an available induction loop has yet been connected. Under unfavourable circumstances this can sporadically lead to interference on the intact loop channels.

NOTE

Loop inductivity range

In the event of loop inductivity outside the recommended range, the available frequency range may be restricted.

DIP (frequency)	Detector Tool	Frequency step
OFF	Low	low (factory setting)
ON	High	High
	Off	none (loop channel switched off)

Tab. 24: Loop frequency settings

11.4 Setting hold time

Separate hold times between 1 and 255 minutes can be set at the detector for each channel. The value 0 corresponds to an infinite hold time. If the loop on a detector channel is covered for longer than the set hold time, the detector channel runs a frequency alignment. The current detuning of the loop channel is reset.

Limiting the hold time

Limiting the hold time can be used, for example, to remove the vehicle parking on the loop automatically once the hold time has ended. The loop can then be reused for subsequent vehicles. Permanent activation caused by faults can also be avoided by setting the hold time appropriately.

DIP (hold time)	Detector Tool	Hold time
ON	0	infinite
	1	1 min

OFF	5	5 min

	255	255 min

Tab. 25: Hold time settings (VEK MNH)

11.5 Setting output mode (signal type)

Various output modes (signal types) can be set for the outputs.

WARNING

Switching off the direction logic (2 channel version)

The direction logic must be switched off to set the output mode, i.e. *Dir. Mode* on the DIP switch must be set to OFF or the direction logic in the Detector Tool must be set to OFF.

DIP (output 2)	Detector Tool	Output signal
OFF	Presence	constant signal (factory setting)
ON	Pulse	Impulse signal
	On	output permanently switched on
	Off	output permanently switched off
	Collective fault	output signal for collective fault
	Loop error	output signal for loop error

Tab. 26: Signal type settings

11.6 Inverting the signal output (signal behaviour)

An inverted or a non-inverted signal output can be selected for all outputs. Consult the chapters pertaining to the signal outputs (see chapter 7.3 "Signal outputs", page 23) and the DIP switch settings (see chapter 10.2 "DIP switch settings", page 32).

NOTE

Controlling signal behaviour

- The factory settings are specified in the short instructions and on the housing.
- The operating principle set is displayed in the *detector tool*.

DIP (inv. out 1)	DIP (inv. out 2)	Detector tool	Signal behaviour
ON	ON	Not inverted	Signal output is not inverted
OFF	OFF	Inverted	Signal output is inverted

Tab. 27: Inversion of output signal

11.7 Behaviour in the event of loop error (error mode)

The way a loop error is handled and what status the assigned output will take is selected in the *Error Mode* setting.

NOTE

Settings in the Detector Tool

The settings can only be changed in the *Detector Tool*.

DIP	Detector Tool	Error mode
	Occupied	as for occupied loops (factory setting)
	Free	as for free loops
	Error	if the <i>Error</i> checkbox is activated, loop errors for this channel will be transmitted. The <i>Error Mode</i> field then shows as <i>Active</i> (factory setting).
	Alignment	if the <i>Alignment</i> checkbox is activated, the duration of the frequency adjustment of the loop will be considered an error. This option is permanently switched off as the default.

Tab. 28: Error mode settings

11.8 Assigning an output to a loop (Assignment)

A loop channel or a travel direction can be assigned to each output when direction detection is activated (dual-channel variants only).

NOTE

Settings in the Detector Tool

The settings can be changed in the *Detector Tool*.

DIP	Detector Tool	Output switching
	None	Output is inactive
	Channel 1 ¹	when loop 1 is covered (factory setting for output 1)
	Channel 2 ^{1,3}	when loop 2 is covered (factory setting for output 2)
	Direction A ^{2,3}	for travel direction A (factory setting for output 1)
	Direction B ^{2,3}	for travel direction B (factory setting for output 2)
	Direction A & B ^{2,3}	for both travel directions

Tab. 29: Assigning the outputs

NOTE

¹ when detuning loops for larger approach thresholds and when direction detection is switched off

² when direction detection is activated

³ for dual-channel variants

11.9 Setting output switching time (impulse time)

The switching time for the outputs can be defined in impulse signal mode.

NOTE

Set impulse duration

The default impulse duration is 200 ms. This can be changed in the *Detector Tool* in increments of 100 ms.

DIP (edge 2)	Detector Tool	Impulse time
OFF	Drive past	when the loop is driven past (factory setting)
ON	Vacant	when the loop is freed up

Tab. 30: Output impulse time

11.10 Setting output times (output time behaviour)

The switch-on delay, the switch-off delay and the minimum signal duration for the output signals can be set in the range from 0 to 25,500 ms in increments of 100 ms.

NOTE

Switch-on delay with short loop coverage

If the loop becomes free before the switch-on delay has expired, no signal is output.

Settings with the *Detector Tool*

The settings can only be changed with the *Detector Tool*.

DIP	Detector Tool	Output time behaviour
	0 – 25,500 ms, Δ 100 ms	Switch-on delay (factory setting: 0 ms)
	0 – 25,500 ms, Δ 100 ms	Switch-off delay (factory setting: 0 ms)
	0 – 25,500 ms, Δ 100 ms	Minimum signal duration (factory setting: 200 ms)

Tab. 31: Duration of output signal

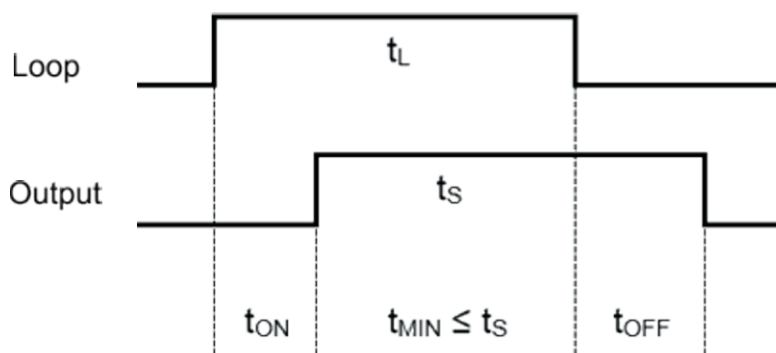

Fig. 13: Output signal time response

Variable	Description
Loop	Loop coverage
Output	Output signal
t_L	Loop coverage duration
t_s	Output signal duration
t_{MIN}	Minimum signal duration
t_{ON}	Switch-on delay
t_{OFF}	Switch-off delay

Tab. 32: Output times legend

11.11 Setting direction detection (dual-channel variants)

Complex evaluation algorithms are integrated into the dual-channel detector for direction-dependent recording of vehicles over double loops. The direction logic generates logical output signals that are given out over the outputs depending on the setting. Parallel to this, the detector autonomously counts the logic signals.

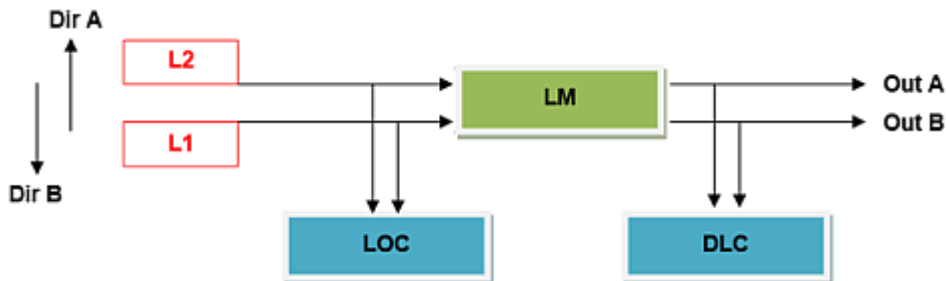

Fig. 14: Direction detection principle

Symbol	Description
Dir A, Dir B	Direction A: Loop 1→Loop 2 or direction B: Loop 2→1
L1, L2	Loop 1 or 2
Out A, Out B	Signal output direction A or B
LM	Logic module
LOC	Loop coverage counter
DLC	Direction logic counter

Tab. 33: Key to symbols

Direction logic system

- With all the logics, the first loop covered determines the direction of counting or of travel. If loop 1 is covered first, the signal output and counting is done for direction A (see chapter 11.12 "Setting direction logic (dual-channel variants)", page 47).
- In the factory settings, travel direction A is output via hardware output 1, and travel direction B via hardware output 2. The assignment of the signal outputs can be changed (see chapter 11.8 "Assigning an output to a loop (Assignment)", page 44).

NOTE

Counter readings in the Detector Tool

- The counter readings are displayed in the *Detector Tool*. It should be noted that the counter overflows at 65,535 (2^{16}) and is automatically erased.
- The counter readings are not protected against power failure!

DIP	Detector Tool	Direction detection
OFF	OFF	Switched off (factory settings)
ON	On	Switched on

Tab. 34: Setting direction detection

11.12 Setting direction logic (dual-channel variants)

A variety of evaluation logics can be set in the logic module, depending on the application.

NOTE

Switching direction detection on

It is only possible to set the direction logic when direction detection is activated!

DIP (Dir. Logic)	Detector Tool	Direction Logic
	D1	Continuous signal 1
	DB	Continuous signal, both loops
OFF	D2	Constant signal 2 (factory setting)
ON	F1	wrong-way driver 1
	F2	Wrong-way driver 2
	BS	both loops
	FE	Feig
	SF	Loop free
	PB	Parking bay
	OFF	No logic selected

Tab. 35: Setting direction logic

The different logics for direction detection are described below.

abbr.	Direction Logic	Signal output	Signal drop	Note
D1	Continuous signal 1	Covering Loop 1	Leaving Loop 1	Output signal in opposite direction only occurs again if both loops were previously free.
DB	Continuous signal both		Leaving Loop 2	
D2	Continuous signal 2	Covering Loop 2		
F1	Wrong-way driver 1	Covering Loop 2	Pulse output with minimum signal duration (default: 200 ms)	Correct behaviour in the case of queues and manoeuvring. Different behaviour in wrong-way driver situation.
F2	Wrong-way driver 2			
BS	both loops			Correct behaviour in the case of queues. Manoeuvring should not occur.
FE	Feig	Leaving Loop 1		Correct behaviour in the case of queues and manoeuvring.
SF	Loop free	Leaving Loop 2		Recording single vehicles and manoeuvring. Queues should not occur.

abbr.	Direction Logic	Signal output	Signal drop	Note
PB	Parking bay	Direction-dependent		For short entrances and exits
Ri1	Direction 1			
Ri2	Direction 2			

Tab. 36: Overview of direction logic

Symbol	Description
	Highlighted direction logic delivers false counts for this setting
	Pulse signal travel direction A
	Pulse signal travel direction B
	Continuous signal
	Loop free
	Loop covered

Tab. 37: Key to direction logic

You can find information on the detailed functions for different traffic situations in the following section.

11.12.1 "Single vehicle" direction logic

	D2	D1	DB	F1	F2	FE	SF	BS	PB Ri1 Ri2	

Fig. 15: Single vehicle direction logic

11.12.2 "Queue" direction logic

	D2	D1	DB	F1	F2	FE	SF	BS	PB Ri1 Ri2	
				A	A			A		
						A				A
									B	
				A	A			A		
						A				A
							A		A	

Fig. 16: Queue direction logic

11.12.3 "Wrong-way driver" 1 direction logic

	D2	D1	DB	F1	F2	FE	SF	BS	PB Ri1 Ri2	
				A	A			A		
				B	B					

Fig. 17: Wrong-way driver 1 direction logic

11.12.4 "Wrong way driver 2" direction logic

	D2	D1	DB	F1	F2	FE	SF	BS	PB	
									Ri1	Ri2
				A	A			A		
						A				A
									B	
					B					

Fig. 18: Wrong-way driver 2 direction logic

11.12.5 "Manoeuvring" 1 direction logic

	D2	D1	DB	F1	F2	FE	SF	BS	PB	
									Ri1	Ri2
				A	A			A		
						A				A
							A		A	

Fig. 19: Manoeuvring 1 direction logic

11.12.6 "Manoeuvring" 2 direction logic

	D2	D1	DB	F1	F2	FE	SF	BS	PB	
									Ri1	Ri2
		High	High							
	High	High	High	A	A			A		
	High	High	High			A				A
	High	High	High							
	High	High	High	A	A			A		B
	High	High	High			A				A
	High		High				A		A	

Fig. 20: Manoeuvring 2 direction logic

11.12.7 "Wrong-way driver in queue" direction logic





	D2	D1	DB	F1	F2	FE	SF	BS	PB	
									Ri1	Ri2
										
				A	A			A		
						A				A
										
									B	
					B					

Fig. 21: "Wrong-way driver in queue" direction logic

11.12.8 Direction Logic „Cross traffic“

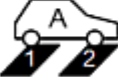
	D2	D1	DB	F1	F2	FE	SF	BS	PB	
									Ri1	Ri2
				A	A			A		
						A				A
									B	
					B					

Fig. 22: Cross traffic direction logic

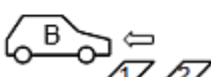
NOTE

False counts

All logics except logic PB in direction 1 deliver false counts in this traffic situation, because they count entries instead of exits!

11.12.9 Direction Logic „Parking bay“

This direction logic is used where for short entrances and exits. Interference to counting due to cross traffic on loop 1 is disabled in this logic. This logic suppresses the impairment of counting by cross traffic on loop 1. It is therefore irrelevant whether loop 1 is laid in the adjoining lane or the manoeuvring area.

WARNING

Positioning of the loops

The positioning of *the* loops is dependent on the direction in which congestion is anticipated. No tailbacks are permitted to occur in travel direction 1 → 2. In travel direction 2 → 1, vehicles will also be correctly counted in congestion, and in this situation the gap between vehicles must release one loop at a time.

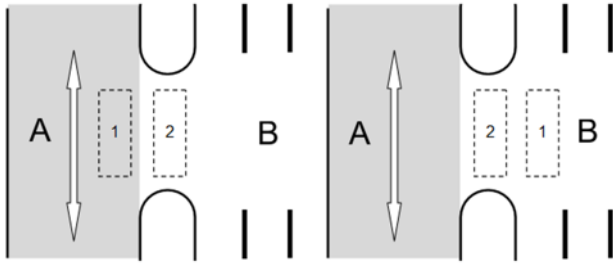

Fig. 23: Parking bay Direction Logic

Symbol	Description
A	passageway
B	Car park
1	Loop 1
2	Loop 2

Tab. 38: Symbols for parking bay

Logic for travel direction 1 → 2

- The counting pulse is triggered as soon as both loops have been completely crossed
- Correct counting with single vehicles
- Correct counting also with manoeuvring
- Congestion and queues are not permitted to occur in travel direction 1 → 2!

Logic for travel direction 2 → 1

- The counting pulse is triggered as soon as loop 2 is vacated in the direction of loop 1.
- Correct counting also with cross traffic
- Correct counting with queues
- Correct counting also when a single vehicle is manoeuvring
- No manoeuvring is permitted to take place in a queue!

12 Maintenance & servicing

Maintenance and repairs

This product does not require any maintenance or servicing.

In the event of malfunctions and faults, please contact the vendor or the manufacturer.

13 Decommissioning

Conditions

System not functioning

The system is not in use.

All work must be carried out by qualified specialists.

Tools

Tools for the system

Always comply with the manufacturer's instructions!

Insulated slotted screwdriver (width 2 – 3 mm)

Decommissioning the detector

1. Switch off all components of the system (observe the manufacturer's instructions).
2. Switch off the power supply to the detector.
3. Check that there is no voltage to any of the supply cables.
 - The detector can be detached.
4. Carefully press down the mounting bracket with the screwdriver and pull the detector off the DIN rail.
5. Pull the terminal blocks out of the input and output sockets.
 - The detector can be detached. Remove all connectors as follows:
6. Loosen the screws holding the terminal blocks with a slotted screwdriver.
7. Pull the cable out of the mounting slots.
 - The detector is disassembled.

14 Disposing of the product



At the end of its service life, dispose of the product in accordance with the valid legal specifications.

15 Key words

A		
Alternating current	23	
Analogue outputs	24	
B		
Basic settings	34, 36	
Bipolar transistors	24	
C		
Changeover contact	24	
Closed-circuit principle	24	
Configuration	34, 36, 39	
Connecting the loops	30	
Connecting the open collector	28	
Connecting the power supply	27	
Connections	17, 23	
Continuous signal	48	
Counter readings	47	
Coverage status	32	
Cross traffic	54	
D		
Default settings	10, 32, 34, 36, 39	
Detector Tool	37	
Device components	17	
Device configuration	37	
Diagnostic data	37	
Diagnostic interface	37	
Diagnostic program	37	
Digital output	24	
DIN rail	26	
DIP switch	17, 33, 34, 35, 44	
Direct current	23	
Direction detection	45, 47	
Direction Logic	47	
E		
Error mode	44	
F		
factory settings	10, 32, 39	
Factory settings	34, 36	
False counts	49	
Flash code	32	
Frequency alignment	32	
Frequency step	42	
Fresh alignment	22	
Functions	39	
I		
Impulse signal	45	
Impulse time	45	
Indicator	17	
Induction loop	30	
Inputs	17, 23	
Interface	37	
Interference	42	
Interpreting travel direction	47, 48	
Inversion	24, 44	
Inverting output signal	44	
L		
Labelling	17	
LED	17	
LED indicator	32	
Loop alignment	22	
Loop assignment	45, 47	
Loop break	22	
Loop closure	22	
Loop error	22, 44	
Loop errors	32	
Loop inputs	23	
Loop occupancy	45, 47	
Loop scanning	22	
Loop status	44	
M		
Manoeuvring	51	
Minimum signal duration	46	
Multiplexing	22, 42	
N		
Normally closed contact	24	
Normally open contact	24	
O		
Open collector outputs	24	
Open-circuit principle	24	
Operation	17	
Oscillatory circuit oscillator	22	
Output assignment	45, 47	
Output signal	22, 44	
Output signals	46	
Output time behaviour	46	
Outputs	17, 24, 44	
P		
Parking bay	48, 55	
Positioning of the loops	55	
Power supply	23	
Pulse signal	49	

Q		
Queue	50	
R		
Relay	24	
Relay outputs	24	
reset button	17, 37	
S		
Safety Extra-Low Voltage	23	
Sensitivity	40	
Service interface	37	
Service program	37	
Setting direction detection	47	
Setting direction logic	47, 48	
Setting hold time	43	
Setting hysteresis	41	
Setting loop frequency	42	
Setting output mode	43	
Settings	17, 34, 36, 39	
Short circuit	22	
Signal behaviour	44	
Signal output	24, 25	
Signal outputs	24, 44	
Signal type	43	
		Single vehicle
		49
		Status indicators
		32
		Switch
		33, 34, 35, 44
		Switch status
		24
		Switching state
		25
		Switching time
		45
		Switch-off delay
		46
		Switch-off threshold
		41
		Switch-on delay
		46
		Switch-on threshold
		40
		T
		Terminal block
		17
		Top hat rail
		26
		Traffic Detector
		17
		Travel direction
		49
		U
		USB
		37
		USB connection
		17
		V
		Vehicle detection
		22
		W
		Wrong-way driver
		48, 50

16 Declaration of conformity



<p>Declaration of Conformity</p> <p>in accordance with the Electromagnetic Compatibility (EMC) Directive 2014/30/EU and RoHS 2 Directive 2011/65/EU and amendment Directive 2015/863/EU</p>	
Product Manufacturer	: FEIG ELECTRONIC GmbH Lange Strasse 4 D-35781 Weilburg Germany Phone +49 6471 3109 0
Product Designation	: VEK MNH1-R24-A VEK MNH2-R24-C VEK MNH2-O24-D
Product Description	: 1 & 2-Channel Induction Loop Detector
<p>FEIG ELECTRONIC GmbH herewith declares the conformity of the product with applicable regulations below.</p>	
Standards applied :	
Electromagnetic compatibility (EMC) Part 6-2: Generic Standards Immunity for industrial environments	DIN EN 61000-6-2:2005
Electromagnetic compatibility (EMC) Part 6-3: Generic standards Emission standard for residential, commercial and light-industrial environments	DIN EN 61000-6-3:2007 / A1:2011 / AC:2012
<u>Weilburg-Waldhausen, 04/06/2019</u>	<u>Dirk Schäfer</u> 
Place & date of issue	Name and signature
<p>This declaration attests to conformity with the named Directives but does not represent assurance of properties. The safety guidelines in the accompanying product documentation must be observed.</p>	

Abb. 24: EU Declaration of Conformity



This Declaration of Conformity is available on the Internet at the following address:
<https://www.feig.de/downloads/>

